

# Rip Sensor

# HC4-R

## TECHNICAL SPECIFICATIONS

### Transmission

Frequency range: 38.9 – 43.4 kHz  
 Source level: 188 dB //1uPa @ 1m  
 Beam width: 55 deg (- 3dB)  
 Range to vessel: Approx. 2500 m (Note 1)

### Operation

Update rate: Approx. 25 sec  
 Max. depth: 1200m

### Battery

Type: NiCd 12V / 600 mAh  
 Charging time: 1.5 hour (QBC-05)  
 Operation time: Approx. 150 hrs

### Measurement

Tension in net: Approx. 3.5 kg

### Weight

In air: 4.2 kg  
 In water: 1.2 kg

### Main dimensions

Length: 243 mm  
 Width: 191 mm  
 Height: 104 mm

### Available options

Mounting kit: 101880  
 Battery pack: 105484  
 Battery charger: QBC-05

### Approvals



Note 1: Depends on acoustic conditions, ships noise, mounting and alignment of sensors and hydrophone.

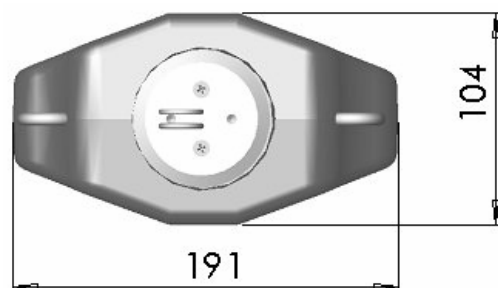
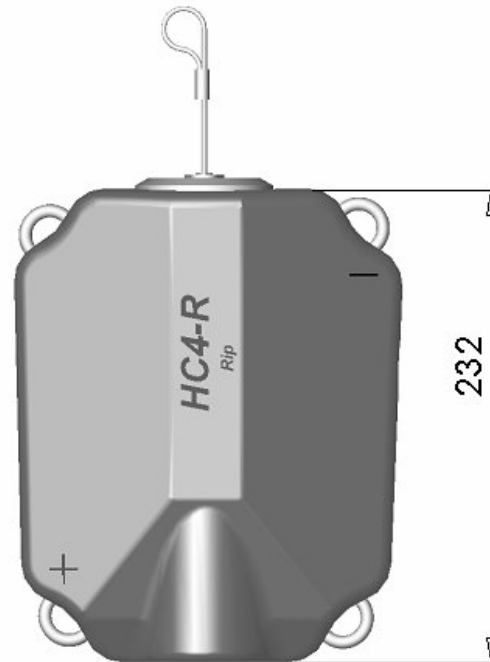

Revision no: 1.0	Product name: HC4-R	Document no. 105786
Revision date: 09.10.2003	Product part no: 104377	

Note: All specifications are subject to change without prior notice